

Sound Attenuator

No. 771-11



Commercial Acoustics
5960 W. WASHINGTON STREET
PHOENIX, ARIZONA 85043-3523
(602) 233-2322 FAX 233-2033

ENGINEERING DATA SHEET

Supersedes No. 771-91

A DIVISION OF METAL FORM MANUFACTURING

DISTRIBUTED BY:
Oeler Industries, Inc.
1-877-406-6473
sales@oeler.com

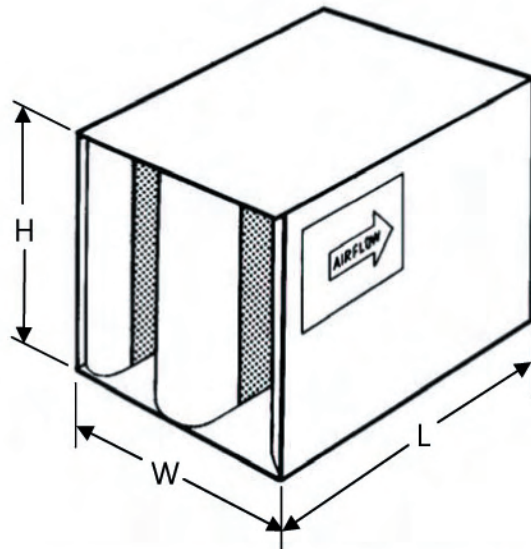

MODEL LFA

RECTANGULAR

NOMENCLATURE EXAMPLE:

WIDTH HEIGHT LENGTH MODEL
24 24 36 LFA

Commercial Acoustics sound attenuators are engineered to achieve a maximum insertion loss and a minimum pressure drop. Commercial Acoustics sound attenuators feature airflow design for efficient aerodynamic performance. Galvanized steel construction and an absorbent, inorganic mineral glass fiber acoustical fill; guarantee excellent reliability and performance.

MODEL NO.	OCTAVE BANDS	(1)	(2)	(3)	(4)	(5)	(6)	(7)	(8)
	CENTER FREQUENCY (Hz)	63	125	250	500	1000	2000	4000	8000
	FACE VELOCITY, fpm	DYNAMIC INSERTION LOSS IN DECIBELS (dB)							
3LFA	-2000	4	13	17	25	30	25	19	16
	-1000	4	12	16	24	29	24	20	16
	0	3	11	15	22	27	27	20	16
	+1000	3	11	14	21	26	27	21	17
	+2000	1	10	13	20	24	27	21	18
5LFA	-2000	7	23	26	39	49	38	26	18
	-1000	6	20	23	37	46	37	27	18
	0	6	17	22	35	43	42	26	16
	+1000	5	15	21	33	41	42	27	17
	+2000	4	14	19	30	38	43	29	18
7LFA	-2000	7	32	36	47	54	43	28	19
	-1000	7	30	30	44	57	44	30	19
	0	3	27	27	41	54	50	30	22
	+1000	3	25	25	39	51	51	31	23
	+2000	3	23	23	37	47	50	32	24
10LFA	-2000	10	49	49	53	51	45	34	23
	-1000	12	43	43	62	61	55	37	23
	0	9	39	39	57	64	63	36	22
	+1000	8	36	36	52	63	61	38	24
	+2000	7	33	33	48	54	50	38	26

THIS TABLE CONTAINS BOTH FORWARD(+) AND REVERSE(-) FLOW ACOUSTIC AND AERODYNAMIC RATINGS BASED ON TEST RESULTS MEASURED IN ACCORDANCE WITH APPLICABLE PORTIONS OF ASTM E477. COPIES OF CERTAIN TEST REPORTS CAN BE FURNISHED UPON REQUEST.

Sound Attenuator

RECTANGULAR MODEL LFA

ENGINEERING DATA

AIR FLOW RATINGS FOR THE 12 x 12 SIZE, SHADED, REPRESENTS BOTH CFM AND FACE VELOCITY IN fpm. USE THIS TO GET THE RATING FOR SILENCER SIZES NOT SHOWN AND FOR MULTIPLE MODULE SILENCER BANKS.

MODEL	3LFA	0.09	0.15	0.22	0.28	0.34	0.38	0.44	0.57	0.70	0.97	1.29	1.62
	5LFA	0.16	0.27	0.38	0.49	0.58	0.66	0.76	0.98	1.21	1.68	2.34	2.79
	7LFA	0.12	0.21	0.30	0.39	0.46	0.52	0.60	0.78	0.95	1.32	1.76	2.20
	10LFA	0.14	0.24	0.34	0.44	0.52	0.59	0.68	0.88	1.08	1.50	2.00	2.50
SIZE W x H	Face Area	AIR FLOW IN CFM											
6 x 12	0.5	227	297	354	402	438	465	500	569	630	743	858	959
6 x 24	1	454	594	707	804	875	930	1000	1138	1260	1485	1715	1917
6 x 36	1.5	681	891	1061	1206	1313	1395	1500	1707	1890	2228	2573	2876
12 x 12	1	454	594	707	804	875	930	1000	1138	1260	1485	1715	1917
12 x 24	2	908	1188	1414	1608	1750	1860	2000	2276	2520	2970	3430	3834
12 x 36	3	1362	1782	2121	2412	2625	2790	3000	3414	3780	4455	5145	5751
18 x 12	1.5	681	891	1061	1206	1313	1395	1500	1707	1890	2228	2573	2876
18 x 18	2.25	1022	1337	1591	1809	1969	2093	2250	2561	2835	3341	3859	4313
18 x 30	3.75	1703	2228	2651	3015	3281	3488	3750	4268	4725	5569	6431	7189
18 x 36	4.5	2043	2673	3182	3618	3938	4185	4500	5121	5670	6683	7718	8627
18 x 48	6	2724	3564	4242	4824	5250	5580	6000	6828	7560	8910	10290	11502
24 x 24	4	1816	2376	2828	3216	3500	3720	4000	4552	5040	5940	6860	7668
24 x 36	6	2724	3564	4242	4824	5250	5580	6000	6828	7560	8910	10290	11502
24 x 48	8	3632	4752	5656	6432	7000	7440	8000	9104	10080	11880	13720	15336
30 x 24	5	2270	2970	3535	4020	4375	4650	5000	5690	6300	7425	8575	9585
30 x 36	7.5	3405	4455	5303	6030	6563	6975	7500	8535	9450	11138	12863	14378
30 x 48	10	4540	5940	7070	8040	8750	9300	10000	11380	12600	14850	17150	19170
36 x 36	9	4086	5346	6363	7236	7875	8370	9000	10242	11340	13365	15435	17253
36 x 42	10.5	4767	6237	7424	8442	9188	9765	10500	11949	13230	15593	18008	20129
36 x 48	12	5448	7128	8484	9648	10500	11160	12000	13656	15120	17820	20580	23004

Helpful Equations: Face Area = (Width in inches x Height in inches) ÷ 144

Face Velocity = CFM ÷ Face Area in Sq.Ft.

Silencer S.P. Loss = $\left(\frac{\text{Face Velocity}}{\text{Tabled Velocity}}\right)^2 \times \text{Tabled S.P. Loss}$

STANDARD CONSTRUCTION FEATURES

Outer Casing — Solid 22GA G90 galvanized steel
 Inner Partitions — Perforated 22GA G90 galvanized steel
 Acoustical Fill — Inorganic mineral glass fiber meeting NFPA 90A, UL 723, and ASTM E84 of sufficient density and packed under at least 5% compression to eliminate voids and to obtain cataloged ratings
 Maximum Differential Pressure — 8 in. wc. as tested in accordance with UL 181, Section 17

Octave Band	1	2	3	4	5	6	7	8	
Frequency, Hz	63	125	250	500	1k	2k	4k	8k	
Length	Face Velocity	Self-Generated Sound Power Ratings (PWL) dB re 10 ⁻¹² WATTS							
ALL LENGTHS	+2000	75	62	61	58	57	58	62	57
	+1000	56	43	41	39	40	46	42	30
	-1000	50	43	45	47	49	51	42	30
	-2000	69	57	56	57	59	61	62	53

When adding any two decibel levels together to an accuracy of 1 dB

Difference between two dB levels	Add to the higher dB level
0 or 1 dB	3 dB
2 or 3 dB	2 dB
4 to 9 dB	1 dB
10 dB or more	0 dB

Air flow ratings shown include static regain. Therefore, if silencers are installed immediately before or after elbows, transitions, at the intake or discharge of the system, or without duct, allowance to compensate for such conditions must be included when calculating the operating static pressure loss across the silencer. Failure to make allowances for these conditions can add several velocity heads to the static pressure loss of the system. All acoustic and aerodynamic performance obtained on a 24" x 24" cross section production unit.

Self-Generated Sound Power, Face Area Adjustment Factors

Face Area	0.50	1	2	4	8	16	32	64	128
Adjustment Factor, dB	-9	-6	-3	0	+3	+6	+9	+12	+15