

Sound Attenuator

No. 772-11



Commercial Acoustics
5960 W. WASHINGTON STREET
PHOENIX, ARIZONA 85043-3523
(602) 233-2322 FAX 233-2033

A DIVISION OF METAL FORM MANUFACTURING

DISTRIBUTED BY:
Oeler Industries, Inc.
1-877-406-6473
sales@oeler.com



ENGINEERING DATA SHEET

Supersedes No. 772-91

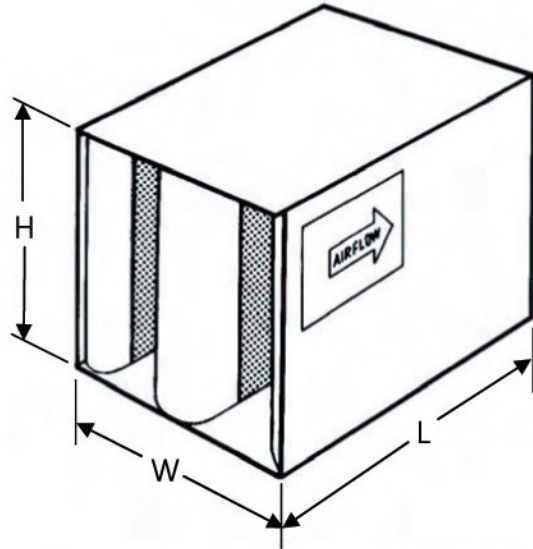

MODEL LFB

RECTANGULAR

NOMENCLATURE EXAMPLE:

WIDTH HEIGHT LENGTH MODEL
24 24 36 LFB

Commercial Acoustics sound attenuators are engineered to achieve a maximum insertion loss and a minimum pressure drop. Commercial Acoustics sound attenuators feature airfoil design for efficient aerodynamic performance. Galvanized steel construction and an absorbent, inorganic mineral glass fiber acoustical fill; guarantee excellent reliability and performance.

MODEL NO.	OCTAVE BANDS	(1)	(2)	(3)	(4)	(5)	(6)	(7)	(8)
	CENTER FREQUENCY (Hz)	63	125	250	500	1000	2000	4000	8000
	FACE VELOCITY, fpm	DYNAMIC INSERTION LOSS IN DECIBELS (dB)							
3LFB	-1000	4	11	15	22	28	24	21	16
	-500	4	11	14	22	27	26	21	17
	0	3	10	14	21	25	27	19	18
	+500	3	9	13	20	25	27	19	17
	+1000	3	9	13	19	25	27	19	17
5LFB	-1000	8	19	24	34	41	31	21	14
	-500	8	18	23	33	40	33	21	15
	0	7	18	22	32	39	37	24	20
	+500	7	17	22	31	39	38	24	20
	+1000	6	16	21	30	38	38	24	20
7LFB	-1000	9	27	32	45	55	43	28	21
	-500	9	26	31	44	54	45	28	23
	0	6	23	30	42	53	48	27	22
	+500	6	22	28	40	51	49	28	23
	+1000	6	21	27	39	50	49	28	22

THIS TABLE CONTAINS BOTH FORWARD(+) AND REVERSE(-) FLOW ACOUSTIC AND AERODYNAMIC RATINGS BASED ON TEST RESULTS MEASURED IN ACCORDANCE WITH APPLICABLE PORTIONS OF ASTM E477. COPIES OF CERTAIN TEST REPORTS CAN BE FURNISHED UPON REQUEST.

Sound Attenuator

RECTANGULAR MODEL LFB

ENGINEERING DATA

AIR FLOW RATINGS FOR THE 12 x 12 SIZE, SHADED, REPRESENTS BOTH CFM AND FACE VELOCITY IN fpm. USE THIS TO GET THE RATING FOR SILENCER SIZES NOT SHOWN AND FOR MULTIPLE MODULE SILENCER BANKS.

MODEL	3LFB	0.09	0.16	0.22	0.28	0.34	0.38	0.44	0.57	0.70	0.97	1.29	1.62
	5LFB	0.11	0.17	0.24	0.31	0.37	0.42	0.49	0.62	0.76	1.04	1.37	1.72
	7LFB	0.11	0.18	0.25	0.33	0.39	0.44	0.51	0.66	0.81	1.12	1.50	1.87
SIZE W x H	Face Area	AIR FLOW IN CFM											
6 x 12	0.5	227	297	354	402	438	465	500	569	630	743	858	959
6 x 24	1	454	594	707	804	875	930	1000	1138	1260	1485	1715	1917
6 x 36	1.5	681	891	1061	1206	1313	1395	1500	1707	1890	2228	2573	2876
12 x 12	1	454	594	707	804	875	930	1000	1138	1260	1485	1715	1917
12 x 18	2	908	1188	1414	1608	1750	1860	2000	2276	2520	2970	3430	3834
12 x 30	2.5	1135	1485	1768	2010	2188	2325	2500	2845	3150	3713	4288	4793
12 x 36	3	1362	1782	2121	2412	2625	2790	3000	3414	3780	4455	5145	5751
12 x 42	4	1816	2376	2828	3216	3500	3720	4000	4552	5040	5940	6860	7668
24 x 18	3	1362	1782	2121	2412	2625	2790	3000	3414	3780	4455	5145	5751
24 x 24	4	1816	2376	2828	3216	3500	3720	4000	4552	5040	5940	6860	7668
24 x 30	5	2270	2970	3535	4020	4375	4650	5000	5690	6300	7425	8575	9585
24 x 36	6	2724	3564	4242	4824	5250	5580	6000	6828	7560	8910	10290	11502
24 x 48	8	3632	4752	5656	6432	7000	7440	8000	9104	10080	11880	13720	15336
48 x 18	6	2724	3564	4242	4824	5250	5580	6000	6828	7560	8910	10290	11502
48 x 30	10	4540	5940	7070	8040	8750	9300	10000	11380	12600	14850	17150	19170
48 x 36	12	5448	7128	8484	9648	10500	11160	12000	13656	15120	17820	20580	23004
48 x 42	14	6356	8316	9898	11256	12250	13020	14000	15932	17640	20790	24010	26838
48 x 48	16	7264	9504	11312	12864	14000	14880	16000	18208	20160	23760	27440	30672

Helpful Equations: Face Area = (Width in inches x Height in inches) ÷ 144

Face Velocity = CFM ÷ Face Area in Sq.Ft.

Silencer S.P. Loss = $\left(\frac{\text{Face Velocity}}{\text{Tabled Velocity}}\right)^2 \times \text{Tabled S.P. Loss}$

STANDARD CONSTRUCTION FEATURES

Outer Casing — Solid 22GA G90 galvanized steel
 Inner Partitions — Perforated 22GA G90 galvanized steel
 Acoustical Fill — Inorganic mineral glass fiber meeting NFPA 90A, UL 723, and ASTM E84 of sufficient density and packed under at least 5% compression to eliminate voids and to obtain cataloged ratings
 Maximum Differential Pressure — 8 in. wc. as tested in accordance with UL 181, Section 17

When adding any two decibel levels together to an accuracy of 1 dB

Difference between two dB levels	Add to the higher dB level
0 or 1 dB	3 dB
2 or 3 dB	2 dB
4 to 9 dB	1 dB
10 dB or more	0 dB

Air flow ratings shown include static regain. Therefore, if silencers are installed immediately before or after elbows, transitions, at the intake or discharge of the system, or without duct, allowance to compensate for such conditions must be included when calculating the operating static pressure loss across the silencer. Failure to make allowances for these conditions can add several velocity heads to the static pressure loss of the system. All acoustic and aerodynamic performance obtained on a 24" x 24" cross section production unit.

Octave Band		1	2	3	4	5	6	7	8
Frequency, Hz		63	125	250	500	1k	2k	4k	8k
Length	Face Velocity	Self-Generated Sound Power Ratings (PWL) dB re 10 ⁻¹² WATTS							
	ALL LENGTHS	+1500	60	58	57	53	51	55	52
+1000		53	50	46	42	41	44	37	31
-1000		49	47	47	48	51	54	46	32
-1500		60	56	54	54	56	60	58	48

Self-Generated Sound Power, Face Area Adjustment Factors

Face Area	0.50	1	2	4	8	16	32	64	128
Adjustment Factor, dB	-9	-6	-3	0	+3	+6	+9	+12	+15

WE RESERVE THE RIGHT TO IMPROVE DESIGN AND SPECIFICATIONS AT ANY TIME WITHOUT NOTICE. ©COPYRIGHT, 2013