

Sound Attenuator

No. 777-11



Commercial Acoustics
5960 W. WASHINGTON STREET
PHOENIX, ARIZONA 85043-3523
(602) 233-2322 FAX 233-2033

A DIVISION OF METAL FORM MANUFACTURING

ENGINEERING DATA SHEET

Supersedes No. 777-95-R1

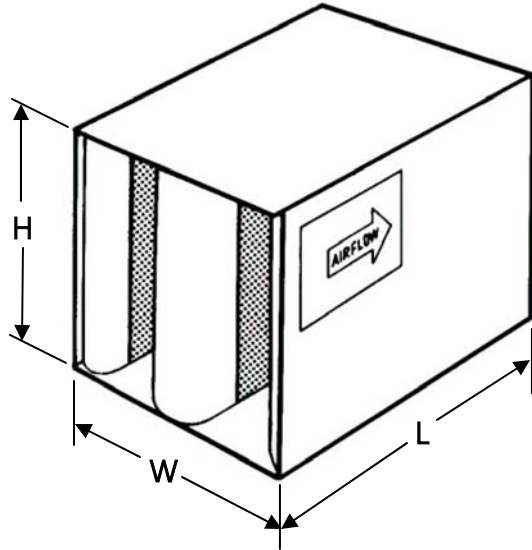

MODEL LP-LF

RECTANGULAR

NOMENCLATURE EXAMPLE:

WIDTH HEIGHT LENGTH MODEL
24 24 36 LP-LF

Commercial Acoustics sound attenuators are engineered to achieve a maximum insertion loss and a minimum pressure drop. Commercial Acoustics sound attenuators feature airfoil design for efficient aerodynamic performance. Galvanized steel construction and an absorbent, inorganic mineral glass fiber acoustical fill; guarantee excellent reliability and performance.

MODEL NO.	OCTAVE BANDS	(1)	(2)	(3)	(4)	(5)	(6)	(7)	(8)
	CENTER FREQUENCY (Hz)	63	125	250	500	1000	2000	4000	8000
	FACE VELOCITY, fpm	DYNAMIC INSERTION LOSS IN DECIBELS (dB)							
3LP-LF	-2000	4	8	11	18	20	17	14	13
	-1000	4	8	10	16	19	17	15	14
	0	3	7	10	15	18	15	14	13
	+1000	3	7	9	14	17	16	14	13
	+2000	2	6	8	13	17	16	14	13
5LP-LF	-2000	6	16	17	27	28	21	17	13
	-1000	6	15	16	25	27	22	16	15
	0	6	13	14	23	26	21	15	14
	+1000	6	13	14	22	25	21	15	14
	+2000	5	12	13	21	25	20	14	15
7LP-LF	-2000	9	20	23	34	36	29	22	15
	-1000	9	19	22	32	35	29	23	17
	0	8	18	21	30	34	28	22	16
	+1000	7	17	19	28	34	27	20	11
	+2000	7	16	18	26	33	26	19	12
10LP-LF	-2000	12	23	31	44	45	30	23	16
	-1000	12	22	31	43	45	30	24	16
	0	11	20	30	43	43	30	23	16
	+1000	10	20	29	42	42	29	21	15
	+2000	10	19	28	42	42	27	20	15

THIS TABLE CONTAINS BOTH FORWARD(+) AND REVERSE(-) FLOW ACOUSTIC AND AERODYNAMIC RATINGS BASED ON COMPARATIVE TEST RESULTS MEASURED IN ACCORDANCE WITH APPLICABLE PORTIONS OF ASTM E477. COPIES OF CERTAIN TEST REPORTS CAN BE FURNISHED UPON REQUEST.

Sound Attenuator

RECTANGULAR MODEL LP-LF

ENGINEERING DATA

AIR FLOW RATINGS FOR THE 12 x 12 SIZE, SHADED, REPRESENTS BOTH CFM AND FACE VELOCITY IN fpm. USE THIS TO GET THE RATING FOR SILENCER SIZES NOT SHOWN AND FOR MULTIPLE MODULE SILENCER BANKS.

MODEL	3LP-LF	0.07	0.14	0.21	0.32	0.48	0.66	0.82	0.98	1.23	1.48	1.64	1.80
	5LP-LF	0.08	0.15	0.22	0.34	0.51	0.70	0.88	1.05	1.32	1.58	1.76	1.93
	7LP-LF	0.09	0.17	0.25	0.39	0.58	0.80	1.00	1.20	1.49	1.79	1.99	2.19
	10LP-LF	0.10	0.19	0.28	0.44	0.65	0.89	1.11	1.34	1.67	2.00	2.23	2.45
SIZE	Face Area	AIR FLOW IN CFM											
W x H													
6 x 12	0.5	457	646	791	976	1195	1398	1563	1712	1914	2097	2210	2318
6 x 24	1	913	1291	1581	1952	2390	2795	3125	3423	3827	4193	4419	4635
6 x 36	1.5	1370	1937	2372	2928	3585	4193	4688	5135	5741	6290	6629	6953
12 x 12	1	913	1291	1581	1952	2390	2795	3125	3423	3827	4193	4419	4635
12 x 24	2	1826	2582	3162	3904	4780	5590	6250	6846	7654	8386	8838	9270
12 x 36	3	2739	3873	4743	5856	7170	8385	9375	10269	11481	12579	13257	13905
18 x 12	1.5	1370	1937	2372	2928	3585	4193	4688	5135	5741	6290	6629	6953
18 x 18	2.25	2054	2905	3557	4392	5378	6289	7031	7702	8611	9434	9943	10429
18 x 30	3.75	3424	4841	5929	7320	8963	10481	11719	12836	14351	15724	16571	17381
18 x 36	4.5	4109	5810	7115	8784	10755	12578	14063	15404	17222	18869	19886	20858
18 x 48	6	5478	7746	9486	11712	14340	16770	18750	20538	22962	25158	26514	27810
24 x 24	4	3652	5164	6324	7808	9560	11180	12500	13692	15308	16772	17676	18540
24 x 36	6	5478	7746	9486	11712	14340	16770	18750	20538	22962	25158	26514	27810
24 x 48	8	7304	10328	12648	15616	19120	22360	25000	27384	30616	33544	35352	37080
30 x 24	5	4565	6455	7905	9760	11950	13975	15625	17115	19135	20965	22095	23175
30 x 36	7.5	6848	9683	11858	14640	17925	20963	23438	25673	28703	31448	33143	34763
30 x 48	10	9130	12910	15810	19520	23900	27950	31250	34230	38270	41930	44190	46350
36 x 36	9	8217	11619	14229	17568	21510	25155	28125	30807	34443	37737	39771	41715
36 x 42	10.5	9587	13556	16601	20496	25095	29348	32813	35942	40184	44027	46400	48668
36 x 48	12	10956	15492	18972	23424	28680	33540	37500	41076	45924	50316	53028	55620

Helpful Equations: Face Area = (Width in inches x Height in inches) ÷ 144

Face Velocity = CFM ÷ Face Area in Sq.Ft.

Silencer S.P. Loss = $\left(\frac{\text{Face Velocity}}{\text{Tabled Velocity}}\right)^2 \times \text{Tabled S.P. Loss}$

STANDARD CONSTRUCTION FEATURES

Outer Casing — Solid 22GA G90 galvanized steel
 Inner Partitions — Perforated 22GA G90 galvanized steel
 Acoustical Fill — Inorganic mineral glass fiber meeting NFPA 90A, UL 723, and ASTM E84 of sufficient density and packed under at least 5% compression to eliminate voids and to obtain cataloged ratings
 Maximum Differential Pressure — 8 in. wc. as tested in accordance with UL 181, Section 17

Octave Band	1	2	3	4	5	6	7	8	
Frequency, Hz	63	125	250	500	1k	2k	4k	8k	
Length	Face Velocity	Self-Generated Sound Power Ratings (PWL) dB re 10 ⁻¹² WATTS							
ALL LENGTHS	+2000	50	45	48	46	50	54	48	41
	+1000	43	36	39	38	35	36	27	27
	-1000	43	41	44	45	48	46	35	26
	-2000	50	49	52	53	54	58	53	46

When adding any two decibel levels together to an accuracy of 1 dB

Difference between two dB levels	Add to the higher dB level
0 or 1 dB	3 dB
2 or 3 dB	2 dB
4 to 9 dB	1 dB
10 dB or more	0 dB

Air flow ratings shown include static regain. Therefore, if silencers are installed immediately before or after elbows, transitions, at the intake or discharge of the system, or without duct, allowance to compensate for such conditions must be included when calculating the operating static pressure loss across the silencer. Failure to make allowances for these conditions can add several velocity heads to the static pressure loss of the system. All acoustic and aerodynamic performance obtained on a 24" x 24" cross section production unit.

Self-Generated Sound Power, Face Area Adjustment Factors

Face Area	0.50	1	2	4	8	16	32	64	128
Adjustment Factor, dB	-9	-6	-3	0	+3	+6	+9	+12	+15