

Sound Attenuator

No. 756-11



Commercial Acoustics
5960 W. WASHINGTON STREET
PHOENIX, ARIZONA 85043-3523
(602) 233-2322 FAX 233-2033

ENGINEERING DATA SHEET

Supersedes No. 756-89-R1

A DIVISION OF METAL FORM MANUFACTURING

DISTRIBUTED BY:
Oeler Industries, Inc.
1-877-406-6473
sales@oeler.com

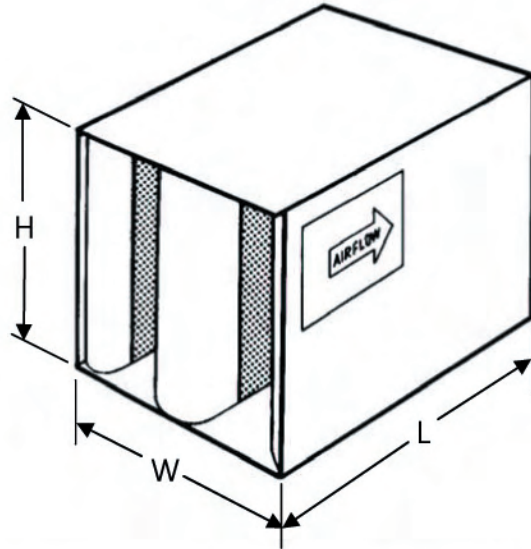

MODEL SP

RECTANGULAR

NOMENCLATURE EXAMPLE:

WIDTH HEIGHT LENGTH MODEL
24 24 36 SP

Commercial Acoustics sound attenuators are engineered to achieve a maximum insertion loss and a minimum pressure drop. Commercial Acoustics sound attenuators feature airfoil design for efficient aerodynamic performance. Galvanized steel construction and an absorbent, inorganic mineral glass fiber acoustical fill; guarantee excellent reliability and performance.

MODEL NO.	OCTAVE BANDS	(1)	(2)	(3)	(4)	(5)	(6)	(7)	(8)
	CENTER FREQUENCY (Hz)	63	125	250	500	1000	2000	4000	8000
	FACE VELOCITY, fpm	DYNAMIC INSERTION LOSS IN DECIBELS (dB)							
3SP	-2000	2	7	15	21	31	33	19	12
	-1000	2	6	13	20	29	33	19	12
	0	1	5	12	19	28	34	21	14
	+1000	1	5	12	18	26	33	23	14
	+2000	0	4	11	17	25	33	23	14
5SP	-2000	4	11	24	37	44	46	24	15
	-1000	3	10	22	36	49	49	25	16
	0	4	8	21	34	48	52	26	14
	+1000	3	7	19	32	46	52	27	16
	+2000	3	7	18	30	43	52	28	16
7SP	-2000	7	16	34	48	49	40	30	15
	-1000	6	13	31	47	53	53	32	16
	0	6	12	28	45	58	62	36	19
	+1000	6	11	26	43	58	62	39	21
	+2000	5	10	24	42	55	53	40	22
10SP	-2000	6	25	36	40	43	37	35	19
	-1000	6	21	38	46	49	47	45	20
	0	8	17	32	44	57	64	53	31
	+1000	8	16	31	44	57	64	55	33
	+2000	7	13	31	45	52	49	52	31

THIS TABLE CONTAINS BOTH FORWARD(+) AND REVERSE(-) FLOW ACOUSTIC AND AERODYNAMIC RATINGS BASED ON TEST RESULTS MEASURED IN ACCORDANCE WITH APPLICABLE PORTIONS OF ASTM E477. COPIES OF CERTAIN TEST REPORTS CAN BE FURNISHED UPON REQUEST.

Sound Attenuator

RECTANGULAR MODEL SP

ENGINEERING DATA

AIR FLOW RATINGS FOR THE 12 x 12 SIZE, SHADED, REPRESENTS BOTH CFM AND FACE VELOCITY IN fpm. USE THIS TO GET THE RATING FOR SILENCER SIZES NOT SHOWN AND FOR MULTIPLE MODULE SILENCER BANKS.

MODEL	3SP	0.05	0.10	0.16	0.21	0.31	0.41	0.51	0.60	0.75	0.89	1.00	1.08
	5SP	0.06	0.11	0.18	0.25	0.38	0.51	0.64	0.75	0.94	1.12	1.26	1.36
	7SP	0.07	0.12	0.18	0.26	0.39	0.53	0.66	0.78	0.97	1.16	1.30	1.40
	10SP	0.09	0.17	0.27	0.39	0.58	0.77	0.96	1.14	1.42	1.70	1.90	2.06
SIZE	Face Area	AIR FLOW IN CFM											
W x H													
6 x 12	0.5	354	477	600	713	875	1012	1130	1230	1371	1500	1588	1650
6 x 24	1	707	953	1200	1425	1750	2023	2260	2459	2742	2999	3175	3300
6 x 36	1.5	1061	1430	1800	2138	2625	3035	3390	3689	4113	4499	4763	4950
12 x 12	1	707	953	1200	1425	1750	2023	2260	2459	2742	2999	3175	3300
12 x 24	2	1414	1906	2400	2850	3500	4046	4520	4918	5484	5998	6350	6600
12 x 36	3	2121	2859	3600	4275	5250	6069	6780	7377	8226	8997	9525	9900
18 x 12	1.5	1061	1430	1800	2138	2625	3035	3390	3689	4113	4499	4763	4950
18 x 18	2.25	1591	2144	2700	3206	3938	4552	5085	5533	6170	6748	7144	7425
18 x 30	3.75	2651	3574	4500	5344	6563	7586	8475	9221	10283	11246	11906	12375
18 x 36	4.5	3182	4289	5400	6413	7875	9104	10170	11066	12339	13496	14288	14850
18 x 48	6	4242	5718	7200	8550	10500	12138	13560	14754	16452	17994	19050	19800
24 x 24	4	2828	3812	4800	5700	7000	8092	9040	9836	10968	11996	12700	13200
24 x 36	6	4242	5718	7200	8550	10500	12138	13560	14754	16452	17994	19050	19800
24 x 48	8	5656	7624	9600	11400	14000	16184	18080	19672	21936	23992	25400	26400
30 x 24	5	3535	4765	6000	7125	8750	10115	11300	12295	13710	14995	15875	16500
30 x 36	7.5	5303	7148	9000	10688	13125	15173	16950	18443	20565	22493	23813	24750
30 x 48	10	7070	9530	12000	14250	17500	20230	22600	24590	27420	29990	31750	33000
36 x 36	9	6363	8577	10800	12825	15750	18207	20340	22131	24678	26991	28575	29700
36 x 42	10.5	7424	10007	12600	14963	18375	21242	23730	25820	28791	31490	33338	34650
36 x 48	12	8484	11436	14400	17100	21000	24276	27120	29508	32904	35988	38100	39600

Helpful Equations: Face Area = (Width in inches x Height in inches) ÷ 144

Face Velocity = CFM ÷ Face Area in Sq.Ft.

$$\text{Silencer S.P. Loss} = \left(\frac{\text{Face Velocity}}{\text{Tabled Velocity}} \right)^2 \times \text{Tabled S.P. Loss}$$

STANDARD CONSTRUCTION FEATURES

Outer Casing — Solid 22GA G90 galvanized steel
 Inner Partitions — Perforated 22GA G90 galvanized steel
 Acoustical Fill — Inorganic mineral glass fiber meeting NFPA 90A, UL 723, and ASTM E84 of sufficient density and packed under at least 5% compression to eliminate voids and to obtain cataloged ratings
 Maximum Differential Pressure — 8 in. wc. as tested in accordance with UL 181, Section 17

Octave Band	1	2	3	4	5	6	7	8	
Frequency, Hz	63	125	250	500	1k	2k	4k	8k	
Length	Face Velocity	Self-Generated Sound Power Ratings (PWL) dB re 10 ⁻¹² WATTS							
ALL LENGTHS	+2000	62	57	52	48	47	51	51	48
	+1000	51	42	34	31	33	28	24	29
	-1000	53	46	44	47	51	52	43	34
	-2000	63	57	55	56	58	64	66	59

When adding any two decibel levels together to an accuracy of 1 dB

Difference between two dB levels	Add to the higher dB level
0 or 1 dB	3 dB
2 or 3 dB	2 dB
4 to 9 dB	1 dB
10 dB or more	0 dB

Air flow ratings shown include static regain. Therefore, if silencers are installed immediately before or after elbows, transitions, at the intake or discharge of the system, or without duct, allowance to compensate for such conditions must be included when calculating the operating static pressure loss across the silencer. Failure to make allowances for these conditions can add several velocity heads to the static pressure loss of the system. All acoustic and aerodynamic performance obtained on a 24" x 24" cross section production unit.

Self-Generated Sound Power, Face Area Adjustment Factors

Face Area	0.50	1	2	4	8	16	32	64	128
Adjustment Factor, dB	-9	-6	-3	0	+3	+6	+9	+12	+15